



EP4024

Mixed Multifunction PIFA

PIFA with 16 DI and 8 DO for mounting in an EXOflex house.

- 8 DO for start/stop, increase/decrease, pulse output, etc.
- DO standard functions such as on-/off-delay, pulse-width modulation, frequency generation, interlocking and error function
- 16 DI for alarm handling, run-time indications, pulse counting etc.
- 12 DI (of 16) standard functions, e.g. filtering, on-/off-delay, run-time measurement
- 4 DI (of 16) with advanced functions (e.g. pulse counting, frequency measurement etc.) and standard functions

EP4024 has 16 digital inputs and 8 digital outputs of the types Standard 24 V DC DI and DO respectively. It is designed for general applications. Potentially free contacts are normally used as input sensors.

EXOflex

EXOflex is a general system for control, regulation, supervision and communication in general automation installations. The system offers great possibilities when constructing many different types of control and regulation systems: outstations in distributed systems, controllers in building automation systems, service gateways in LANs and on the Internet, etc.

The system is of a modular design and provides unique opportunities for adapting the number and type of inputs and outputs required, as well as the type of communication needed.

EXOflex consists of a housing and a selection of PIFA units. One power-PIFA must always be present in each house.

Installation

EP4024 can generally be mounted in any of the compartments in an EXOflex house. It is of a standard design and size and can quickly and simply be slotted into place.



All electrical connections to external equipment are easily attainable on plug-in screw connectors.

For more information on how to install PIFA:s, see the instruction for EH11-S...41-S / EH10-S...40-S / ECX2.

EP4024 handles difficult electrical environments

The process connections are, as a group, galvanically insulated from each other and from the internal control logic circuits by a protective barrier, which is bridged by optocouplers. If necessary, the isolation from other circuits can be retained by using a separate power supply. Each process connection has active transient protection, which is led to a special EMI ground (disturbance protection ground) or to protective ground. This provides for optimal handling of difficult electrical environments.

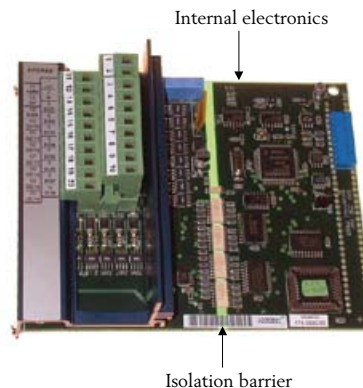

The principles of the isolation barrier

Prepared for redundant power supply

The parts of the PIFA closest to the process get their power from an external source, which is normally the same as the source supplying the whole EXOflex-unit with power. To handle power outage situations, it could also be power supplied from an alternative source, e. g. 9035 with external battery. See the product sheets for EP1011 and 9035.

Connections

The last four inputs are of the type Software Advanced and should especially be used for pulse counting, if required. They can also be used as SO inputs for connecting certain energy meters, etc. The remaining 12 are of the type Software Normal.

- **Power supply**

The EMI earth must be connected to the earth rail or equivalent, to prevent disturbances.

The 0 V connection must also be grounded. This is normally done at the power unit's negative pole.

- **Standard 24 V DC DI**

This type of input is used for reading off floating (potential free) contacts and are active high.

A yellow LED for each input shows its current status.

Process Connections

The external contact's one end is connected to the input and the other to +C. The +C output is current limited and short circuit proof.

- **Standard 24 V DC DO**

This type of current source output is mainly constructed for use with DC-relays, lamps etc.

The outputs' driving stage is powered from the external supply

Each output is current limited, short circuit protected and has overheat protection. Apart from the current limiting for each individual output, there is also total limiting for all of the outputs together.

A yellow LED for each output shows its status.

Process Connections

An external load is connected between the output and -C.

Technical data

Supply voltage	24 V DC
tolerance	18...30 V DC
electronically fused	to 2.5 A
power consumption with no load	50 mA
+C output for DI, level	= Supply voltage
max load	100 mA
Internal power consumption	5 V, 60 mA
CE	This product conforms with the requirements of European EMC standards CENELEC EN 61000-6-1 and EN 61000-6-3 and carries the CE-mark.

Digital inputs

Number of inputs	16
Type input 1–12	Normal
Type input 13–16	Advanced
Logic 0	0...5 V
input current at 0 V	0 mA
input resistance	5.7 kOhm
Logic 1	11...30 V
input current at +24 V	4 mA
Shortest pulse length for detection	
software type normal	9 ms
software type advanced	4.5 ms

Digital outputs

Number of outputs	8
Maximum total continuous load on all outputs	2.0 A
Type	current source
Current is fed from the PIFA-unit's power supply connection	
Output voltage at logical zero	max 2 V/12 uA
Output current at +24 V (source)	
max continuous load per output	min 400 mA
max continuous load per output at max. 30°C run temp	min 500 mA
max transient load (20 ms)	min 1 A

SO inputs

The last four inputs can individually be activated as a so-called SO input by using a jumper on the PIFA card. SO inputs, sometimes referred to as Type 2 inputs, have a somewhat different electrical specification than standard, see below.

Digital input 13-16 activated as type 2 inputs (SO inputs)

Logic 0	0...5 V
input current at 0 V	0 mA
input resistance	5.7 kOhm
Logic 1	11...30 V
input current at 24 V	15 mA

Wiring

Pin no	Signal	Function
1	+C	+24 V DC. Output for digital inputs DI.
2	-C	0 V. Reference for digital outputs DO.
3	EMI ground	This terminal is connected internally to the PIFA's frame and to internal protective circuits. It should be connected to the ground rail with a separate, heavy wire.
4	DO1	Digital output 1, type Standard 24 V DC
5	DO2	Digital output 2, type Standard 24 V DC
6	DO3	Digital output 3, type Standard 24 V DC
7	DO4	Digital output 4, type Standard 24 V DC
8	DI1	Digital input 1, type Standard 24 V DC
9	DI2	Digital input 2, type Standard 24 V DC
10	DI3	Digital input 3, type Standard 24 V DC
11	DI4	Digital input 4, type Standard 24 V DC
12	DI5	Digital input 5, type Standard 24 V DC
13	DI6	Digital input 6, type Standard 24 V DC
14	DI7	Digital input 7, type Standard 24 V DC
15	DI8	Digital input 8, type Standard 24 V DC
16	+24 V	Power supply +24 V DC.
17	0 V	Power supply 0 V. The 0 V-connection is normally grounded at the supply source, so as to define the potential to earth reference and to compensate for disturbances and transients from I/O signals.
18		
19	DO5	Digital output 5, type Standard 24 V DC
20	DO6	Digital output 6, type Standard 24 V DC
21	DO7	Digital output 7, type Standard 24 V DC
22	DO8	Digital output 8, type Standard 24 V DC
23	DI9	Digital input 9, type Standard 24 V DC
24	DI10	Digital input 10, type Standard 24 V DC
25	DI11	Digital input 11, type Standard 24 V DC
26	DI12	Digital input 12, type Standard 24 V DC
27	DI13	Digital input 13, type Standard 24 V DC
28	DI14	Digital input 14, type Standard 24 V DC
29	DI15	Digital input 15, type Standard 24 V DC
30	DI16	Digital input 16, type Standard 24 V DC

Product documentation

Document	Type
EH11-S...41-S / EH10-S...40-S / ECX2	Instruction for EXOflex houses and the EXOflex processor ECX2
EXO System Manual	Manual covering the EXO System

Head Office Sweden
 Phone: +46 31 720 02 00
 Web: www.regin.se
 Mail: info@regin.se

Sales Offices
 France: +33 14 171 46 46
 Hong Kong: +852 24 07 02 81
 Singapore: +65 67 47 82 33
 Germany: +49 30 77 99 40



THE CHALLENGER IN BUILDING AUTOMATION