



ROOM CONTROLLERS WITH AUTOMATIC SEASON CHANGEOVER, ON-OFF DB-TA-363

FUNCTION

2-pipe fan coil with 3-speed motor fan control for room temperature with:

- knob for temperature setting;
- automatic season changeover, referred to the temperature of water supplied to the fan coil and measured by the water sensor;
- manual 3 motor speed
- thermostatic fan/continuous fan/off selection;
- red and green leds for the active function indication (heating or cooling);
- internal or remote temperature sensor (optional).

TYPE	VT/VC/OFF	3-SPEED	LOCAL S/W
DB-TA-363-436	•	•	auto

auto season changeover selection (S/W) by water sensor

Note: The controllers are supplied with water sensor model: NTA020-027P.

On request:

optional remote 2 m cable sensor, selectable by jumper; ordering code: NT0220-NTC10-02.

TECHNICAL DATA

- Power supply:** 230 Vac \pm 10%, 50/60 Hz
Max load: 6 A
Output: 1 relay 6 A 230 Vac
Power cons.: 1 W
Sensor: NTC 10K, air sensor and water sensors
Setpoint: +5...+30 °C; mechanical limitation of the setpoint adjustment
Differential: < 0.5 K
Working: 0...+40 °C
 10...90% r.h. (without condensing)
Storage: -20...+70 °C
 < 95 % r.h.
Housing: ABS fireproof according to UL94 V-0 color (RAL 9010)
Protection: IP30, class II
Size: 144 x 82 x 34 mm
Weight: 210 g

WIRING DIAGRAM

Terminal connections for 2-pipe air conditioning and heating systems.

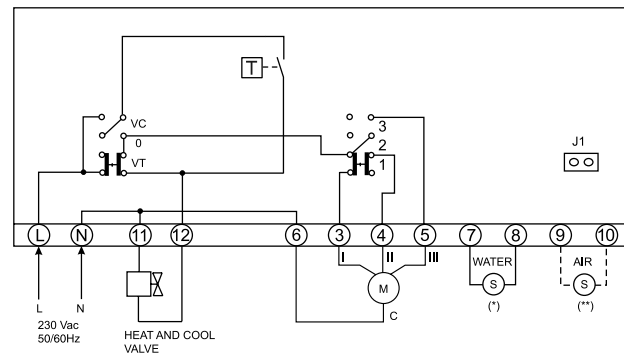

(*) water sensor for automatic season changeover according to the following logic diagram:



(**) remote sensor (optional): J1 open

