



# CMF10

Pre-programmed, configurable controller for simple applications

The CMF10 range of controllers controls temperature. They are intended for DIN-rail mounting.

- Language independent
- Simple configuration via the backlit display
- Input for an external setpoint device

CMF10 is a pre-programmed controller that can be used for control of temperature in air handling unit and heating applications. It is a stand-alone controller for simpler applications. CMF10 is extremely easy to install, commission and control.

CMF10 uses a display with an encoder knob, making its built-in menu system very easy to use. Settings are entered by turning the encoder knob to a desired parameter/value. A value is then approved by pressing the knob.

## Models

The CMF series comprises two different types, CMF5U and CMF10.

CMF5U has 5 in-/outputs and CMF10 has 10 in-/outputs. CMF10 is available in two versions:

- CMF10 with 24 V AC supply voltage
- CMF10-230 with 230 V AC supply voltage

*CMF has been developed according to our Ready-Steady-Go concept, which simplifies every step from installation to management.*

## Applications CMF10 and CMF10-230

- Pre-loaded with several application modes
- 24 V or 230 V AC supply voltage
- Week-based clock / calendar function

CMF10 is pre-programmed with a choice of five different control modes:

1. Supply air control
2. Supply air control with outdoor compensation
3. Cascaded room / extract air temperature control
4. Radiator circuit control
5. Domestic hot water control

## Inputs and outputs

CMF10 has

- 2 analogue inputs, PT1000
- 1 SPI input for an external setpoint device
- 1 universal input, PT1000 or digital
- 2 digital inputs
- 3 digital outputs
- 2 analogue outputs, 0...10 V DC

## Internal clock

CMF10 has a built-in week-based real-time clock with a number of different scheduler alternatives.

## Easy to install

CMF is suitable for DIN-rail or cabinet mounting. Since the terminals are detachable all connections can be made before CMF is installed.

### Display handling

All setting and configuration is performed using the display and encoder knob on the front of the controller.

The menu information shown on the display is organised in a tree fashion. By using the knob you can move in between menus, set values etc.

In any of the configuration menus, pressing the encoder knob will activate change mode. You can then turn the knob to move between choices or set values. A second press of the knob will accept the choice.

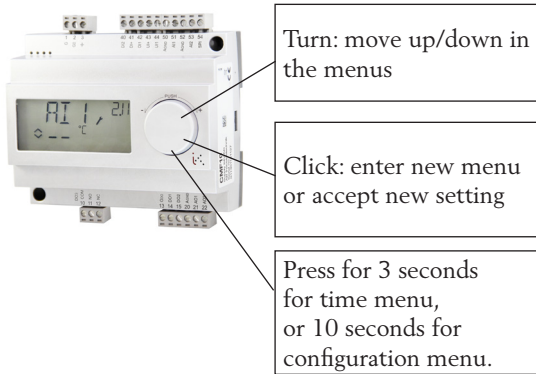

### Display - Base level

This is an example of the display when in Base level view mode. It is normally shown when there is no operator activity.



The Base display shows current time and actual value.

There are bar-graphs showing the current output levels together with symbols showing how the outputs have been configured (Heating, Cooling or Damper etc).

There is also a symbol showing which of the five control modes is configured, as well as an alarm symbol that is displayed in the event of an alarm condition. The fan symbol (control modes 1, 2 and 3 only) is lit as long as the fan indication input is activated.

To see the values and status of all in- and outputs, simply turn the knob counter-clockwise until the text I/O is displayed and then press it. To return to the Base display, click on the knob and then turn it clockwise.

The menu system is divided into three levels:

- Base level: view mode
- 3-second level: clock and scheduler settings
- 10-second level: configuration area

### Display information

The display can show the following information

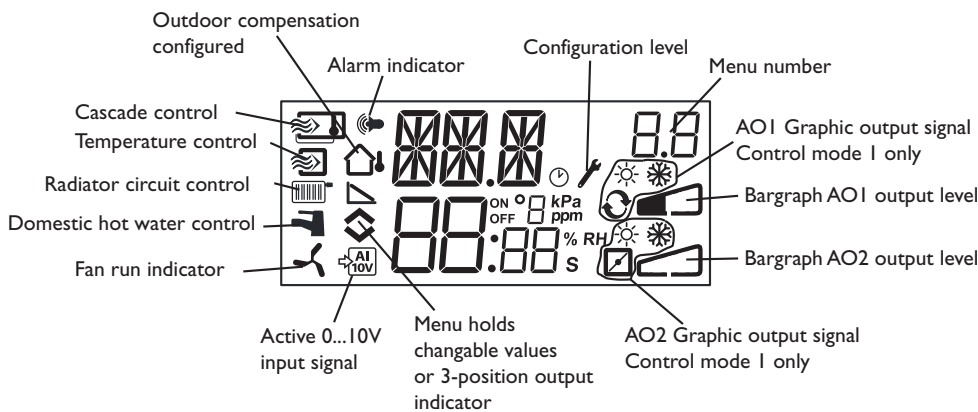

## Configuration

All configuration menus lie in the 10-seconds level. This level is accessed from the Base Display by pressing and holding the encoder button for 10 seconds.

There are numerous configuration menus covering all available options and combinations.

In some cases, making a certain choice in one menu will mean that you will only see certain other menus. For example, the menu for setting the damper minimum limit is only shown if you have configured AO2 to be a damper control output.

## Function overview

### Selectable control functions

1. Supply air control
2. Supply air control with outdoor compensation
3. Cascade connected room/extract air temperature control
4. Radiator circuit control with outdoor curve
5. Domestic hot water control

### CMF is capable of handling the following control modes

#### Ventilation

According to points 1, 2 and 3 above:

- P- or PI-control
- Can control two analogue outputs in sequence, or one 3-position actuator via two digital outputs
- Damper control, with settable minimum supply air amount
- Control of frost protection or frost protection thermostat with manual reset
- High temperature limit switch
- Electric heater cool-down function
- Digital scheduler
- Start/stop of fan via built-in relay for 230 V AC
- Digital input for extended running via timer
- Input for an external setpoint device
- Alarm management in the display as well as sum alarm output
- Heat maintaining function
- As of revision 21, a frost protection thermostat can be connected to UI1 for control modes 1-3.

### Radiator circuit control

According to point 4 above:

- P- or PI-control
- Output 0...10 V or 3-position 24 V AC
- Settable outdoor compensation curve
- Extra correction of outdoor curve (increase at approx. zero degrees outdoor temp.)
- Room sensor can be connected for adaption of outdoor curve
- Room setpoint can be set via an external setpoint device
- Pump stop/Pump exercise
- Alarm management in the display as well as sum alarm output

### Domestic hot water

According to point 5 above:

- PID control
- 0...10 V output
- Periodic overheating to decrease risk of Legionella
- Alarm management in the display as well as sum alarm output

## Application examples

CMF10 can be configured to any one of the following control modes. The three modes on this page have much in common and will therefore be treated in a single section.

### Supply air control

The supply air temperature is kept at the setpoint value by controlling the output signals on AO1 and AO2. A single PI control loop is used.

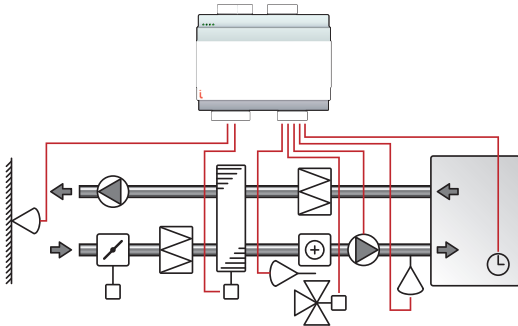

This control mode requires a sensor, "Supply air sensor", on AI1.

### Supply air control with outdoor compensation

The supply air temperature is kept at the setpoint value by controlling the output signals on AO1 and AO2. A single PI control loop is used. The setpoint is automatically adjusted according to the outdoor temperature.

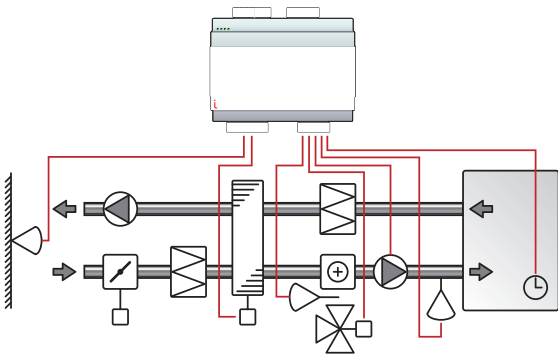

This control mode requires two sensors, "Supply air sensor" on AI1 and "Outdoor sensor" on AI2.

### Cascade connected room/extract air temperature control

An offset in room temperature, which if desired can be set via the external setpoint device, will adjust the supply air temperature setpoint so as to eliminate the room temperature offset. One PI and one P control loop are used. The supply air temperature can be minimum and maximum limited.

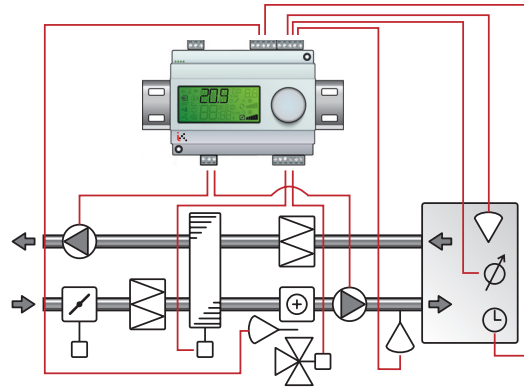

This control mode requires two sensors, "Supply air sensor" on AI1 and either "Room sensor" or "Extract sensor" on AI2.

### Analogue outputs

The analogue outputs can be configured to the following combinations (valid for all three examples on this page):

AO1	AO2
1. Heating	-
2. Cooling	-
3. Heating	Cooling
4. Heating	Heating
5. Cooling	Cooling
6. Heating	Dampers
7. Cooling	Dampers

### 3-position control

Instead of the analogue outputs, CMF can be configured for 3-position control (increase / decrease). Only the following output choices will then be available:

- Heating
- Cooling

DO1 is used for increase signal and DO2 for decrease. This option cannot be combined with alarm output.

A single PI control loop is used.

### Radiator circuit control with outdoor curve

The water temperature setpoint is changed according to the outdoor temperature. A single PI control loop is used. A room temperature sensor can be added to give corrective action if the room temperature differs from the setpoint.

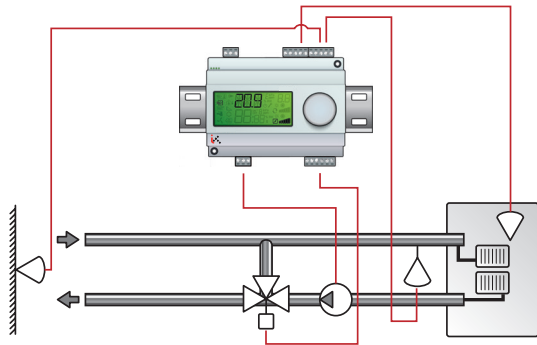

This control mode requires two sensors, "Supply temperature" on AI1 and "Outdoor sensor" on AI2.

A room temperature sensor can also be connected to UI1, permitting the room temperature offset to correct the supply temperature. Wire UI1 as an analogue input.

### 3-position control

Instead of the analogue outputs, CMF can be configured for 3-position control (increase / decrease). DO1 will then be used for the increase signal and DO2 for the decrease signal. This option cannot be combined with an alarm output.

### Domestic hot water control

The water temperature is kept constant by controlling the output signal on AO1. A single PID control loop is used.

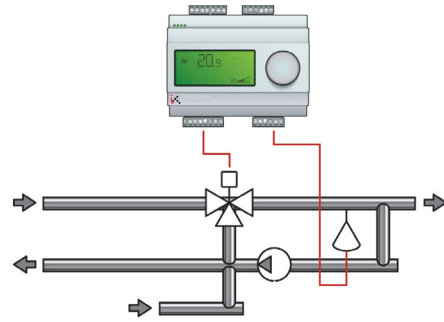

This control mode requires a sensor, "Supply water temperature", on AI1

**Technical data**

Supply voltage	CMF10: 24 V AC $\pm 15\%$ , 50...60 Hz CMF10-230: 230 V AC +10%, -15%, 50...60 Hz
Internal consumption	4 VA
Ambient temperature	0...50°C
Storage temperature	-20...+70°C
Ambient humidity	Max. 90 % RH
Display	Numeric/graphic, backlit
Protection class	IP20
Material casing	Polycarbonate, PC
Terminal blocks	Disconnectable, so-called lift type for cable cross-section 2.5 mm <sup>2</sup>
Weight	CMF10-230: 370 g CMF10: 215 g incl. terminals
Colour	Cover: White Bottom part: Dark grey



**Low Voltage Directive (LVD) standards:** CMF-230 conforms to the requirements of the European Low Voltage Directive (LVD) 2006/95/EC through product standard 60730-1 and EN 60730-2-9.

**EMC emissions & immunity standards:** This product conforms to the requirements of the EMC Directive 2004/108/EC through standards EN 61000-6-1 and EN 61000-6-3.

**RoHS:** This product conforms to the Directive 2011/65/EU of the European Parliament and of the Council.

**Inputs**

Analog inputs	Three
AI1	PT1000 sensor, working range 0...+84°C, accuracy $\pm 0.5^\circ\text{C}$
AI2	PT1000 sensor, working range -30...+54°C, accuracy $\pm 0.5^\circ\text{C}$
SPI	PT1000 setpoint device, working range 0...40°C, accuracy $\pm 0.5^\circ\text{C}$
Universal input	One analogue or digital input
AI	PT1000 sensor, working range 0...84°C, accuracy $\pm 0.5^\circ\text{C}$
or DI	Potential-free closing contact
AGND	Reference for AI and for UI when used as analog input
UI+	Reference for UI
Digital inputs	Closing potential-free contact
DI+	Reference for DI

**Outputs**

AO	Two analogue and three digital outputs
DO1 and DO2	0...10 V DC; 8 bit D/A short-circuit protected
DO3	Triac controlled, 24 V AC, 0.5 A continuous Change-over (SPDT) relay, 230 V AC, 5 A

## Wiring

CMF10

CMF10-230V

Terminal	Designation	Operation
0	G	24 V AC
1	G0	CMF10 only
2		

Terminal	Designation	Operation
0	L	230 V AC
1	N	
2		CMF10-230 only

Terminal	Designation	Operation
10	Common	 Change-over relay, 5A
11	NO	
12	NC	
13	G	Reference for DO1 and DO2
14	DO1	Digital output
15	DO2	Digital output
20	AGND	Reference for AO1 and AO2
21	AO1	0...10 V DC output
22	AO2	0...10 V DC output
40	DI2	Digital input
41	DI+	Reference for DI1 and DI2
42	DI1	Digital input
43	UI+	Reference for UI1
44	UI1	Universal input PT1000 or Digital
50	AGND	Reference for AI1
51	AI1	PT1000 temperature sensor input
52	AGND	Reference for AI2 / SPI
53	AI2	PT1000 temperature sensor input
54	SPI	Input PT1000 setpoint device

## Dimensions

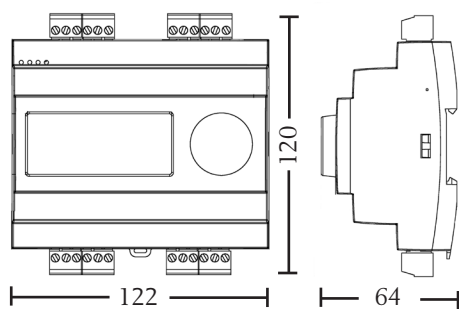

(mm)

## Product documentation

Document	Type
Manual	Manual CMF10
Instruction	Instruction CMF10

### AB Industrietechnik Srl

Via Julius Durst, 70 - 39042 Bressanone (BZ) - Italy

Tel. +39 0472/830626 - Fax +39 0472/831840

E-mail: [info@industrietechnik.it](mailto:info@industrietechnik.it)Homepage: [www.industrietechnik.it](http://www.industrietechnik.it)