



## VALVE ACTUATORS 600 N

SE6

### APPLICATION

Electric actuators are suitable to drive valves VFS/VFSF. The assembly actuator/valve body is done directly and easily without any tool. The actuator can be adapted automatically to the valve (proportional model). Actuator is fitted with manual override by a hexagonal key.

Actuator is equipped with a torque limit device to power off motor when end stop is reached. SE6M24 has an additional feedback signal output. An internal LED indicates the current state of the actuator: adjustment, control, end stroke position, error condition.

TYPE	FORCE N	STROKE mm	POWER SUPPLY Vac 50/60 HZ	ACTION	POWER CONS. VA
SE6M24	600	16.5	24 ± 10%	modulante 0...10 Vdc 4...20 mA	6.0
SE6F24	600	16.5	24 ± 10%	2 / 3 point (floating)	5.0
SE6F24S	600	16.5	24 ± 10%	2 / 3 point (floating)	5.0
SE6F230	600	16.5	110...240 ± 10%	2 / 3 point (floating)	8.0
SE6F230S	600	16.5	110...240 ± 10%	2 / 3 point (floating)	8.0

Accessory	Description
	ADV1 - Adapter for 2S and 3S valves series Industrietechnik (gray body, obsolete models)
	ADV2 - Adapter for 2S- and 3S- valves series Industrietechnik (black body, obsolete models)
	ADV3 - Adapter for VMB/VSB valves series Controlli

S models with 2 auxiliary microswitches 230 Vac 3A

### TECHNICAL DATA

#### Power supply:

- SE6M24 24 Vac ± 10% 50/60 Hz
- SE6F24 24 Vac ± 10% 50/60 Hz
- SE6F230 110...240 Vac ± 10% 50/60 Hz

**Auxiliary switches:** 3(I) A 230 Vac

**Running time:** approx. 80 sec.

**Manual override:** by 3 mm hexagonal key  
**Action:** direct / reverse selectable by jumper

**Working conditions:** 0...50 °C

**Humidity range:** 10...90 % r.h. (without condensing)

**Storage temp.:** -20...70 °C

< 95% r.h.

**Connections:** cable section 1 mm<sup>2</sup> length 1 m

**Housing:** opaque polycarbonate

**Base:** PA6 V0

**Bracket:** PA6 30 GF V0

**Max working temp.:** -30/+140 °C (bracket)

**Traction breaking**

**load:** 1500kg/cm<sup>2</sup> (bracket)

**Protection class:** IP54, class II (SE6F230), class III (SE6M24, SE6F24)

**Dimensions:** 112 x 82 x 148 mm

**Weight:** 470 g

#### SE6M24:

INPUT SIGNAL (Y)	IMPEDANCE (R <sub>in</sub> )
0...10 Vdc	~ 65 kOhm
0...4 Vdc	~ 65 kOhm
6...10 Vdc	~ 65 kOhm
2...10 Vdc	~ 65 kOhm
4...20 mA	~ 500 Ohm

### WIRING DIAGRAM

#### SE6M24

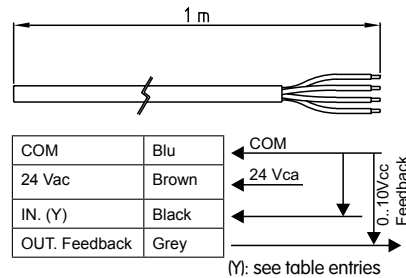

#### SE6F24(S) - SE6F230(S)

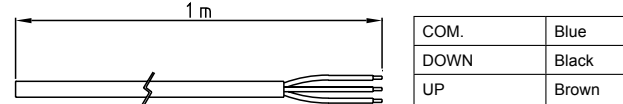

auxiliary switches for models SE6F24S - SE6F230S

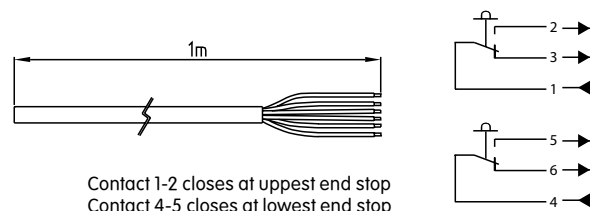

**STATUS INDICATION BY LED (INTERNAL)**

- GREEN slowly blinking:** self-adjusting in upper position (SE6M24)
- RED SLOWLY blinking:** self-adjusting in lowest position (SE6M24).
- GREEN FAST blinking:** modulating to upper position.
- RED FAST blinking:** modulating to lower position.
- GREEN lighted:** motor on upper end stop or is moving toward upper end stop (SE6M24).
- RED lighted:** motor on lowest end stop or is moving toward lowest end stop (SE6M24).

- ORANGE lighted:** error to move on stroke, the motor tries 3 times to unlock and then 3 times to self-adjust (SE6M24).
- ORANGE blinking:** permanent error after tries to do the stroke done (SE6M24).
- RED and GREEN blinking:** jumpers setting not correct (SE6M24)
- All LEDs OFF:** control position reached out of end stops
- Slow blinking:** 2 flashing / second
- Fast blinking:** 8 flashing / second

**DIRECT / REVERSE ACTION SE6M24**

- DA: 0 Vdc shaft in upper position (A-AB valve port closed)
- 10 Vdc shaft in lowest position (A-AB valve port open)
- RA: 0 Vdc shaft in lowest position (A-AB valve port open)
- 10 Vdc shaft in upper position (A-AB valve port closed)
- Factory setting: DA, input signal 0...10 Vdc

INPUT SIGNAL	J1	J2	J3	J5	J4
0...10 Vdc					
0...4 Vdc					
6...10 Vdc					
2...10 Vdc					
4...20 mA					
<b>DIRECT ACTION</b>					
<b>REVERSE ACTION</b>					

- Jumper unmounted
- Jumper mounted

**Self-adaption stroke (only for SE6M24):**

When the unit is powered on at the first time, it is necessary to do a cycle to adapt the motor to the real stroke. To do so the motor must be mounted on the valve and it must be powered on. To begin the cycle take away the cover, push the key (fig. 1) until the motor turns (red led flashing) then release it. On this phase the motor moves downwards in order the stem can couple automatically to the valve. When this phase has been completed the motor moves upwards to close the valve completely (green led flashing). The two end stops of the valve have been then memorized and they will be used during regulation. If the motor is unmounted from the valve and then mounted again, the cycle for adapting the motor to the valve stroke must be repeated again.

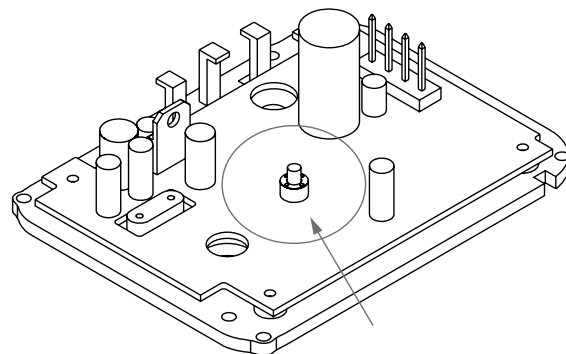
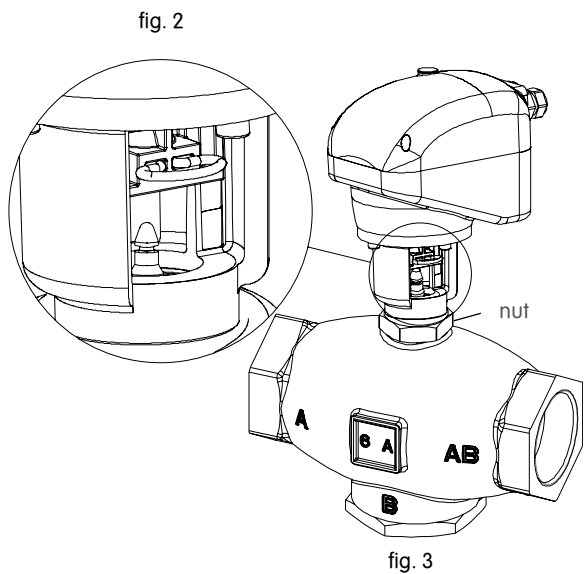

fig. 1

**Mounting**

Control that the clips for automatic coupling is inserted on the seat fig. 2 / fig. 4 and the motor shaft is on the upper position. Mount the motor on the valve and screw the nut present on the valve body fig. 3. Power on the motor (see paragraph regarding self-adaptation stroke) to allow automatic coupling on the valve stem. To take away the motor from the valve put the shaft on lowest position, extract the clip, unscrew the fixing nut and remove the motor vertically.



**Microswitch setup:**

Put the motor on lowest position. Position the two cams on snap-on point of microswitches (cams must be perpendicular to microswitches, fig. 5). Put the motor on upper position. Position the cam 1 on the snap-on point of microswitch on top position (cam perpendicular to microswitch on top position, fig. 6), take care to not change the position of cam 2.

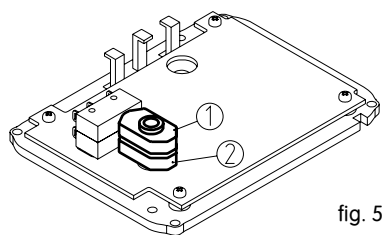

fig. 5

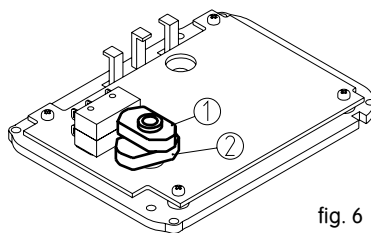
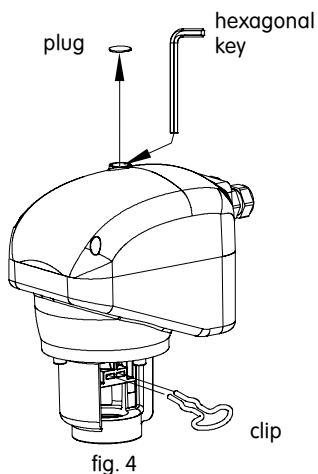

fig. 6

Note: microswitches are used only for end stops detection. The microswitches can't be set on position different from end stops.

**Manual override:**

In order to open or close the valve manually, it is necessary to remove the plug fig. 4, insert a 3 mm hexagonal key. Push the hexagonal key downwards and turn clockwise to extract the motor shaft and counterclockwise to retract it. Such operation must be done when power supply is off!



**OVERALL DIMENSIONS (mm)**

